

# Using carbon dioxide for fodder conservation

Alexander Femistoklovich Triandafilov, Alexander Yurievich Lobanov,  
Aleksi Gennadyevich Tulinov, Mikhail Yurievich Shlyk

*The Federal State Budgetary Scientific Institution  
Research Institute of Agriculture of the Komi Republic,  
167023, Russia, Komi Republic, Syktyvkar, Rucheynaya street, 27*

## Abstract

Fodder conservation is the inhibition of the enzymes in the forage mass with the use of chemical, biological or gas conservants. A liquid chemical diffuses into the environment of plant materials in two phases: liquid and vapor. The processes of vapor and liquid diffusion in the plant material are classified as unidirectional diffusion, and are described by the general equation of Fick, where the most important is the kinematic diffusion coefficient of the conservant. Since, as a medium of diffusion, plant materials are a complex environment that consists of liquid, vapor, gas, stems and leaves containing bound moisture, etc., for performing a research related to diffusion of conservants in the grass environment, it is necessary to theoretically calculate the values of the kinematic diffusion coefficients for used acids and gases. As a result, theoretical values of the diffusion coefficients for gas and chemical conservants have been obtained to be used for substantiating the design parameters of the equipment. The theoretical data have been confirmed by a laboratory experiment. The multi-factor second order Box-Benkin experiment allowed obtaining the optimum data for introducing carbon dioxide into the haylage as a conservant. It has been found that when harvesting haylage with the density of 290...330 kg/m<sup>3</sup> and the humidity of 53-55%, introduction of carbon dioxide in the dosage of 0.40-0.50·10<sup>-3</sup> m<sup>3</sup>/kg and consumption of 0.50-0.60 m<sup>3</sup>/h ensures uniform distribution of the conservant injected through one atomizer into the center of a hay roll with the diameter of D = 1 m and the length of L = 1 m, thus confirming the theoretical data about gas conservant diffusion in hay mass.

**Keywords:** forage, conservants, diffusion of substances, haylage, grass raw materials.

## INTRODUCTION.

Introduction of the technology of fodder conservation with pressing into large rolls weighing up to 1,000 kg, with subsequent sealing with film, allows farms to minimize manual labor and increase productivity of the process. However, the quality of the obtained fodder leaves much to be desired. According to the Republican Station of Chemicalization of the Komi Republic, in 2012-2015 only 34% of class I forage were preserved with the use of the new technology. Given the fairly high cost of producing forage in sealed containers, such ratio of classes is of course unacceptable. One of the ways to improve fodder quality is using conservants of various nature in the process of fodder conservation.

In its essence, fodder conservation belongs to complex scientific and practical problems due to the fact that it combines the interaction of several factors, including plants, a chemical (conservant), various equipment, an animal organism and humans. Using a certain technology, the man introduces the conservant into the green mass to be eaten by the animals. It is therefore necessary to consider all details in order to get the most biological, economic and environmental benefits from interaction of the factors above at least cost of money, energy and health [5].

Formation and accumulation of the fodder mass is based on biochemical processes in plant cells. The processes that form and accumulate the fodder mass are to be maintained, while the processes that destroy nutrients in the fodder are to be held down or stopped completely. The first kind of the process occurs in growing plants, the second one – in mowed plants deprived of nutrients inflow from the soil. The sooner the life processes in mowed plants are stopped, the better, and with less nutrients loss the fodder will be stored [3].

A fundamental condition of life is metabolism, which includes two simultaneously occurring opposite processes – the process of assimilation (anabolism), where the body builds its cells from substances from the environment, and the process of dissimilation (catabolism, decay) with dissociation of substances and release of energy, and formation of end products extracted from the organism according to the following scheme [3];

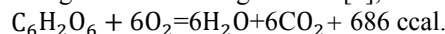

All these processes occur with the help of specific proteins – enzymes. Therefore, all methods aimed at increasing the number and activity of enzymes involved in the processes of assimilation will contribute to synthesis of live mass, and all methods aimed at reducing the number and activity of these enzymes will contribute to catabolism, breakdown of substances in a living system and ultimately - death.

It follows from the foregoing that any life processes can be significantly slowed down or stopped by reduction or complete suppression (inhibition) of the corresponding enzymes' activity. Chemical preservation of forages is inhibition of enzymes in the fodder mass using chemical substances [4].

## MATERIALS AND METHODS.

In the heart of the conservant action in the environment of plant materials is the phenomenon of diffusion. The vapor phase of the chemical preparation diffuses into the external structure of plants at the rate proportional to the gradient of the diffusing substance concentration. The natural barrier for diffusion in plant raw materials are stems and leaves of plants, which slow down the process of vapor diffusion.

In course of diffusion of the vapors of the conservant in the vegetation layer, moisture vapors are absorbed by the plants according to the law described by equation of Brunauer, Emmett, and Teller [2] for plant materials with the humidity of 75%.

$$U_p = U_1 \frac{CC_w}{1 - Y(2+C) + Y^2(L-1)}$$

where:  $U_p$  is the equilibrium moisture content in the material in the respective processing mode, kg/kg;

$U_1$  is the equilibrium moisture content before treatment, kg/kg;

$\varphi$  is relative humidity of the steam-and-air mixture, normalized; and

$C$  is the constant that characterizes the material, normalized.

Solving this equation in relation to value  $U_p$  under the condition of the maximum moisturization of the plant mass with vapors of preservative solution, we will find that the moisture content in plants increases by 0.00016%, i.e. by the value of experiment error. Therefore, the influence of moisture absorption from the conservant vapors by plants on the process of conservation may be neglected.

Interacting with protein carriers, the liquid phase of the conservant diffuses inside the plants, where the solvent is vegetable juice, and is directly involved in the process of fodder acidification. The processes of vapor and liquid diffusion in the plant material are classified as unidirectional diffusion by the following equation:

$$N_A = -D_{AB} \frac{C_A + C_B}{C_B} \frac{dC_A}{dX_B}$$

where  $N_A$  is the number of moles of a substance diffusing in one direction through a unit of cross section in a unit of time, mol;

$D_{AB}$  is the kinematic diffusion coefficient,  $m^2/sec$ ;

$C_A$  is the concentration of the diffusing substance,  $kg/m^3$ ;

$C_B$  is the concentration of the diffusion environment,  $kg/m^3$ ;

$X_B$  is the length in the direction of diffusion, m; and

$\frac{dC_A}{dX_B}$  is the concentration gradient of the diffusing substance in coordinate X.

The minus sign before the gradient of concentration shows that concentration of  $C_A$  decreases in the direction of diffusion. The greater is the resistance the diffusion of the molecules in substance A meets, the greater is the concentration gradient  $\frac{dC_A}{dX_B}$ . The value of this resistance is proportional to the concentration of molecules in the environment where diffusion occurs. It will be the smaller, the greater is the resultant velocity of the molecules of solvent in the direction opposite to the direction of substance A. The kinematic coefficient of diffusion  $D_{AB}$  is the proportionality factor between the flow of component A and its gradient in the direction of diffusion.

Due to the absence of an elaborate theory of the liquid aggregate state, it is still impossible to exactly imagine the mechanism of diffusion in liquids. Attempts to

develop a theoretically sound method of calculating the kinematic coefficient of diffusion in liquids have not been satisfactory [2]. Due to the fact that the physico-chemical properties of vegetable juice and water are very much similar, the use of semiempirical methods for calculating the diffusion coefficient in binary mixtures seems possible with regard to diffusion of the liquid phase of the chemical in the plant juice.

For aqueous solutions, Otmer and Tecker proposed a formula in the temperature range  $t$  between  $10^\circ$  and  $20.5^\circ C$  with the mean error of  $\pm 5.0\%$  [2].

$$D_A = \frac{14 \cdot 10^{-9}}{\mu_v^{1.1} V_M^{0.6}}, m^2/sec$$

Where:  $D_A$  is the coefficient of diffusion in a diluted aqueous solution,  $m^2/s$ ;

$V_M$  is the molar volume of the liquid  $m^3/mole$ ; and

$\mu_v$  is the dynamic viscosity coefficient of water at  $20^\circ C$ .

For an established process of chemical elements diffusion in wet plant material, the equation of the first law of Fick holds [2]:

$$n_a = -D_{AB} F \frac{C_H + C_K}{2} t$$

where  $n_a$  is the number of moles of the diffusing preservative, moles;

$D_{AB}$  is the kinematic diffusion coefficient of conservant A in vegetable raw material B,  $m^2/s$ ;

$F$  is the cross-section area of diffusion,  $m^2$ ; and

$t$  is time of process, sec.

A solution of this equation for practical purposes is defining the geometric parameters for arranging atomizers for feeding the conservant into the plant raw material, depending on its composition and moisture. The obtained data were studied with the use of a laboratory experiment.

The studies were performed in accordance with the plan of the second order Box-Benkin four factor experiment, where the response function was taken as the temperature of self-heating fiddler  $Y_1$  ( $t$ ,  $^\circ C$ ), protein content  $Y_2$  (%), and fodder units  $Y_3$  (un/kg). Factors and levels of variation are shown in Table 1. The factors variation levels were determined according to theoretical calculations of grass material pore volume [1]. The number of experiments was 27, repeated three times.

The device for the laboratory experiment was developed in the Federal State Funded Research Institution Research Institute of Agriculture of the Komi Republic. The layout is shown in Figure 1, and consists of cylinder 1 with 40 liters of carbon dioxide with a shut-off valve 2 connected to pressure reducer 3 with a flow meter. Pressure reducer is connected via flexible hose 4 with 6 mm inner diameter to tube 5, at the end of which an sprayer made of stainless steel is attached. The sprayer is placed into the middle of the batch of grass mass 7, which is sealed into strong large plastic bag 7 with hermetically closing mouth. After the conservant is injected, thermometer 6 is installed, and the bag is sealed.

**Table 1. Factors, their levels and intervals of variation**

Coded factor designation	Name of the factor, its designation and measuring unit	Factor level		
		Low - 1	Main 0	High + 1
$x_1$	Density of haylage mass pressing $p$ , kg/m <sup>3</sup>	250	300	350
$x_2$	Conservant dosage $q$ , 10 <sup>-3</sup> m <sup>3</sup> /kg	0.30	0.45	0.60
$x_3$	The volume of hay mass in the treatment area of one sprayer $Q$ , 10 <sup>-3</sup> m <sup>3</sup>	48	96	144
$x_4$	Gas flow rate $V_o$ gas, m <sup>3</sup> /h	0.30	0.50	0.70

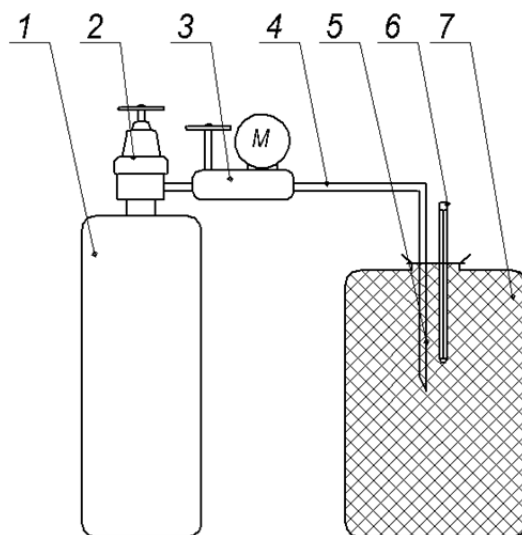
**Figure 1. Layout of the laboratory installation: 1 – gas cylinder; 2 - valve; 3 – reducer; 4 – hose; 5 – pipe with sprayer; 6 – thermometer; 7 – grass batch in a sealed package.****Table 2. Calculation of chemical conservants diffusion coefficient**

Names of chemical conservants	Solubility in water, $\mu$ at 20 °C	Density of the solution kg/m <sup>3</sup> at concentration, %		Molecular weight of the solution M 10 <sup>3</sup> , kg/mol at concentration, %		Molar volume of the solution V1 10 <sup>6</sup> , m <sup>3</sup> /mol at concentration, %		Coefficient of diffusion D·10 <sup>9</sup> , m <sup>2</sup> /s at concentration of the solution, %	
		90	30	90	30	90	30	90	30
Formic acid	1.782	1,220	1,066	46	26.4	37.73	24.8	1.58	2.04
Propionic acid	1.090	992	998	74.08	34.8	74.68	34.8	1.05	1.06
Acetic acid	1.219	1,049	1,015	60.05	30.8	57.24	30.4	1.23	1.80
Complex of low-molecular acids	$\infty$	1,100	1,030	48.3	27.1	43.91	25.3	1.45	2.01
Benzoic acid	0.3	1,199	1,060	122.12	49.2	101.85	46.4	0.87	—
Sodium pyrosulphite	45.5	1,480	1,144	190.1	69.8	128.45	61	0.76	1.19

Herbal raw material with the humidity of 53- 55% with the length of cutting of 50-70 mm from perennial legume-cereal grasses mowed during the period of earing was used. The results were mathematically processed in application STATGRAPHICS Plus 5.0.

### RESULTS

Calculation of the kinematic diffusion coefficients in an aqueous solution for known chemical conservants is shown in Table 2.

As a result of the laboratory experiment, we have obtained the following decoded regression models of

influence of the studied factors on the temperature of fodder self-heating ( $t$ , °C), protein content (%), fodder units (un/kg), verified for the adequacy by the  $F$  Fisher test (probability  $p=0.95$ ):

$$Y_1 = 27.75 - 5.41x_1 - 2.00x_2 + 1.00x_3 + 0.58x_4 + 1.21x_1^2 - 1.15x_2^2;$$

$$Y_2 = 10.98 + 1.54x_1 + 1.13x_2 - 0.61x_3 - 0.57x_4 + 0.25x_2^2;$$

$$Y_3 = 0.79 + 0.14x_1 + 0.13x_2 - 0.03x_3 - 0.12x_4 - 0.07x_2^2 + 0.13x_4^2.$$

### DISCUSSION.

From the analysis of these data it follows that with decreasing the concentration of solutions of chemical conservants (formic, acetic acids, a complex of low-molecular acids and sodium nitrosulfite), the diffusion coefficient increases by 29-56%, which greatly increases the speed and thus the reliability of wet fodder conservation. However, in preservation of haylage in a packing with formic acid, the temperature inside the bundles increased to 32 °C after 24 hours of storage. This means that the chemical conservant with the concentration of formic acid of 30% injected into the fodder in the calculated points in accordance with the calculated value of diffusion coefficient  $D = 2.04 \cdot 10^{-9} \text{ m}^2/\text{s}$  (or  $2 \cdot 10^{-3} \text{ mm}^2/\text{s}$ ) will ensure penetration into the stems and leaves of pressed grass mass with the density of pressing of 500 kg/m<sup>3</sup> and a bale diameter of 1 m after 230 hours at best. So, simultaneously with ensuring uniform diffusion of the liquid chemical conservant, it is necessary to ensure reliable sealing of the plastic film or the extruded sealed sleeve for reliable fodder isolation from oxygen.

The process of diffusion in liquids is many times slower than that in gases. The value of kinematic coefficient  $D$  defined also according to Fick's law for liquids is  $10^4$ - $10^5$  times less than the value of the diffusion coefficient for gases. The calculated coefficient of carbon dioxide diffusion in air at  $t = 17.6$  °C and the atmospheric pressure of 751 mm mercury will be  $0.1653 \cdot 10^{-4} \text{ m}^2/\text{s}$ .

When harvesting haylage pressed into rolls 1 m wide and 1 m in diameter, the picker of the press forms a ribbon of grass raw materials 1 m wide and 30-50 mm thick. In this case, density of pressing is 500-600 kg/m<sup>3</sup>. This means that the gas conservant injected into the middle of a packet bale during loading diffuses towards the outer surface of the bale in 16 hours. Introduction of carbon dioxide inside the bale in addition to the carbon dioxide emitted as a result of natural processes reduces the time of suppressing life (metabolism) of the grass [1].

This hypothesis was confirmed by the laboratory experiment, during which influence of factors on the response function was assessed based on the analysis of two-dimensional cross-sections of the obtained regression models. As a result of assessment, the following regularities have been established:

- Density of pressing  $p$  has significant influence on all studied response functions ( $Y_1, Y_2, Y_3$ ). This is due to the fact that the content of air in the haylage mass is inversely proportional to the density of pressing. Density of pressing is most important in the interval between 250 and 310 kg/m<sup>3</sup>. In this case the temperature is reduced from 35°C to the acceptable 27°C, and collection of protein at 9.3...11.2%, and fodder units – 0.64...0.94 un/kg is ensured;

- Positive influence of introducing carbon dioxide into the haylage mass has been established. Introduction of 0.40 m<sup>3</sup>/kg of carbon dioxide into the silage helps keep the self-heating temperature of the grass mass packed with the density of 250 kg/m<sup>3</sup> at the level of 35°C. Increasing the dosage to 0.50...0.60 m<sup>3</sup>/kg with the pressing density of 270...310 kg/m<sup>3</sup> ensures ripening of the silage at the comfortable self-heating temperature – 20...30°C;

- Gas flow rate has little influence on the studied parameters. With the same concentration of the conservant, an increased flow rate results in an increased temperature, which may be associated with deterioration of oxygen displacement from herbal raw materials by carbon dioxide. Flow rate of 0.50...0.60 m<sup>3</sup>/h is optimal for processing haylage;

- The positive effect of injecting carbon dioxide is observed with the concentration of 0.40...0.50- $10^{-3}$  m<sup>3</sup>/kg with the pressing density of 290...330 kg/m<sup>3</sup>. With these values, the temperature of haylage mass self-heating does not exceed 25...30°C, the content of crude protein is 9.3...12.6%, and the content of fodder units – 0.80...0.87 un/kg.

### CONCLUSIONS

Using carbon dioxide as a conservant for storing haylage is an efficient way of improving fodder quality. The hypothesis about efficiency of carbon dioxide diffusion inside the haylage mass, which allows to inhibit microbiological processes in raw material, has been proven. Studies have shown that carbon dioxide in the dosage of 0.40...0.50- $10^{-3}$  m<sup>3</sup>/kg is most effective for storing haylage with the density of 290...330 kg/m<sup>3</sup> and the humidity of 53...55%. The flow rate of 0.50...0.60 m<sup>3</sup>/h ensures an uniform distribution of the conservant injected through a sprayer into the center of the haylage roll with diameter  $D_r = 1$  m and length  $L_r = 1$  m.

### REFERENCES

- 1 Bakanov, V. N. (1977). *Ispol'zovanie uglekislogo gaza pri konservirovanii zelenyh rastenij* [Using carbon dioxide for green plants preservation]. Technology of fodder production, storage and use. Moscow, pp. 32-36.
- 2 Bretschneider, S. (1966). *Svoystva gazov i zhidkostej* [Properties of gases and liquids]. Translated from the Polish. Moscow: Chemistry, pp. 536.
- 3 Horhin, S. N. (2013). *Mikrobiologicheskie osnovy konservirovaniya zelenyh kormov* [Microbiological bases for preservation of green fodder]: study guide. St. Petersburg: Prospekt Nauki, pp. 192.
- 4 Taranov N. G. (1982). *Chemical preservation of fodder* (2nd ed.). Moscow: Kolos, pp. 143.
- 5 Triandafilov, A. F. (1986). *Sposoby i tehniczeskie sredstva povysheniya jeffektivnosti obrabotki sena himicheskimi konservantami* [Methods and technical means to improve the effectiveness of the treatment chemical hay preservatives]. Candidate of Technical Sciences inaugural dissertation. Leningrad-Pushkin: NIPTIMESKH NZ RSFSR, pp. 156.